

BW Converting

barrywehmler
bw
betterworld

Change for the better



449 E-Commerce Paper Mailer Machine

The faster, easier way to produce paper mailing bags

W+D Winkler +
Dünnebier

Produce paper mailing bags quickly and easily

E-commerce packaging for smaller items is faster and better than ever

With BW Converting's W+D 449 E-Commerce machine, you are ideally positioned to produce paper mailing bags specially developed to meet the needs of online retail.

This production powerhouse offers a reduced, simplified workflow while increasing the on-the-belt output of mailer bags from a single machine.

- Up to 300 bags per minute
- Environmentally-friendly packaging made from recyclable materials for a better world
- The best alternative to plastic shipping bags
- Very fast filling, packing, and sealing
- Low transport volume
- Easy to open and return



THE FASTER WAY
Produce up to 300 mailing bags per minute / 18,000 bags per hour



THE BETTER WAY
Paper mailing bags made from recyclable materials



THE EFFICIENT WAY
Fewer production touches, fast filling, packing, and sealing, and low transport volumes



ATTRACTIVE BRAND EXPERIENCE
Appealing look and feel of paper with ability to add branded graphics



Mailing bags are used for approximately 80% of total e-commerce shipments that are under 4 lbs

Mailing bag formats and sizes

A wide range of production options from one machine. Switch from different bag formats each offering flexibility in both material and weight.

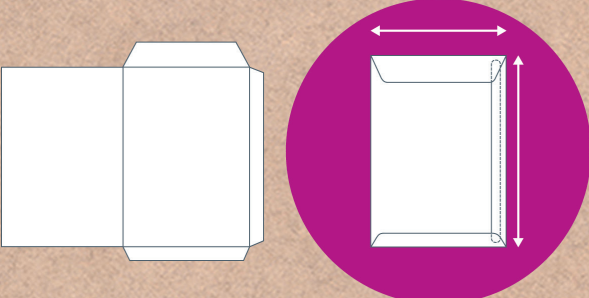

Standard Mailing Bag

Minimum width:	229 mm / 9 in
Maximum width:	380 mm / 15 in
Minimum height:	305 mm / 12 in
Maximum height:	480 mm / 19 in

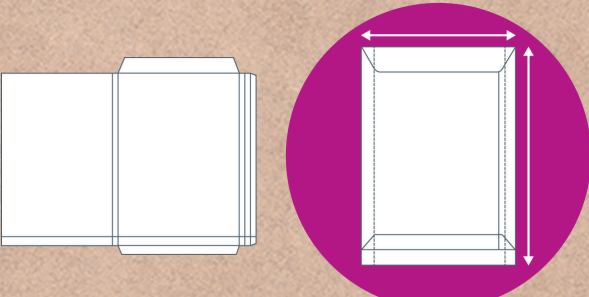

Gusseted Mailing Bag

Minimum width:	229 mm / 9 in
Maximum width:	380 mm / 15 in
Minimum height:	305 mm / 12 in
Maximum height:	480 mm / 19 in
Standard gusset (open):	80 mm / 3-1/8 in
Optional gusset (open):	127 mm / 5 in

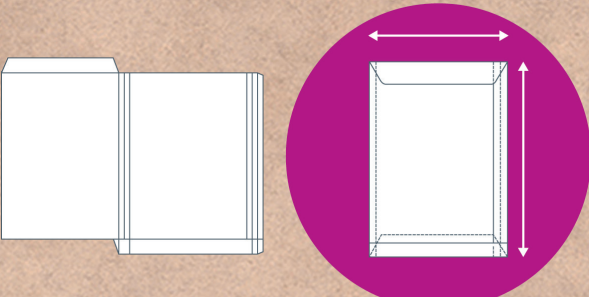

Zero-Waste Mailing Bag

Minimum width:	229 mm / 9 in
Maximum width:	380 mm / 15 in
Minimum height:	305 mm / 12 in
Maximum height:	480 mm / 19 in
Maximum gusset (open):	80 mm / 3-1/8 in
Optional gusset (open):	127 mm / 5 in

W+D 449 E-Commerce Paper Mailer Machine - approximately 26 meters / 85 feet long

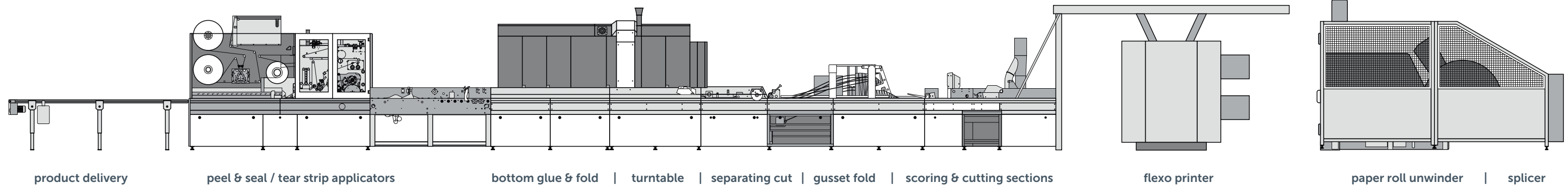



Get the best performance combined with economical production

With BW Converting's W+D 449 E-Commerce machine, you'll benefit from the fastest solution for the complete production of high-quality paper mailing bags. A high-level of automation, different extension stages, and a variety of production options, each involving just one pass, allow for maximum flexibility and productivity.

Efficiency

- All-in-one process from the roll to the finished mailing bag
- Maximum speed of up to 300 bags per minute
- Innovative turn-table for better product control
- Automatic paper splicer allows for uninterrupted high-speed production
- End-of-line bundling and packing

Versatility

- Produce a variety of mailing bag shapes – also suitable for complex types
- Produce a wide range of paper types and weights ranging from 90-150 GSM
- One to four-color flexo printing available

Quality

- Automatic tension control for consistent high-quality mailing bag products
- Applicator for two peel and seal strips and one tear strip in a single in-line process
- Variety of tear strip perforation shapes
- Finger lift feature for fast, convenient sealing

Operator friendly

- Automatic tension control for consistent high-quality mailing bag products
- Presets for folding and cutting cylinders
- Bag format uses independent cutting sections
- Few format-size parts required
- Nearly toolless changeovers
- Save options for job settings for faster repeat jobs
- Central operation via moveable HMI
- Low noise levels during production
- Open design for easily visible production process

